

Lockley Skimmer 45® Runner Sharpener Plans

©2014 Wind Products U.S.A Wellsville PA 17365

Materials

- 6" x 6" x 20" wood block
- Two 1/2" wood lag bolts
- 3" x 5/32" diameter wood dowel
- Sandpaper
- Wood glue
- Light weight machine oil

Tools

- Saw with 45° Miter or Miter Box
- Level
- Pencil
- Drill, 7/16" and 5/32" drill bits
- Small hammer
- Belt sander with 120 Grain sandpaper

Preparation

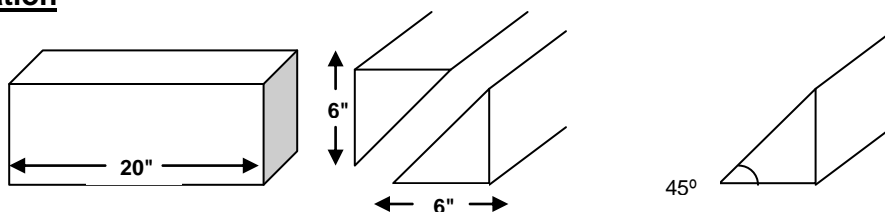

1. Set your saw to 45° to cut the 6" x 6" block in half diagonally to form two triangular shaped pieces. Discard one of the halves or give it to a friend.
2. Using the same 45° miter cut 1" off of the top of the triangle to form a trapezoid. Sand the cut edges.

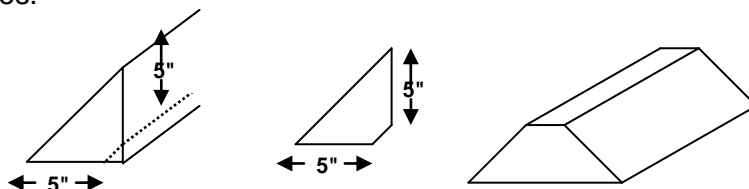

3. Place a runner on the side of the trapezoid so that the bottom edge is about 3/8" above the top of the wood block. Move the runner up or down until the smaller hole is on the wood block and the bottom edge of the skate is above the block. Mark the 3/16" hole location. Make sure the bottom edge of the runner is level, and then mark the 1/2" hole location.

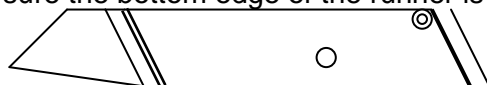

4. Put the runner on the other side of the trapezoid block and mark the hole locations. Make sure the small hole is on the same end of the block.
5. Drill a 5/32" pilot hole for the small dowel on both sides of the trapezoid block where you marked the 3/16" runner hole location. Make the hole about 1" deep. Squeeze a small amount of glue into each hole.
6. Cut the 5/32" dowel in half into two, 1-1/2" pieces. Insert a small amount of glue on one end of the dowel and insert one piece into the pilot hole on the trapezoid block. Gently tap into place. Repeat this process on the other side.
7. Drill a 7/32" pilot hole on both sides of the trapezoid block where you marked the 1/2" runner hole. Congratulations, your runner sharpener is ready to use!

Lockley Skimmer 45® Runner Sharpener Plans

©2014 Wind Products U.S.A Wellsville PA 17365

How to use the runner sharpener

1. Mount your runners on each side of the trapezoid block.
 - a. Slide one runner over the 5/32" dowel.
 - b. Firmly fasten the runner to the block using the 1/2" lag bolt.
 - c. Turn the trapezoid block around and secure the second runner as you did the first.

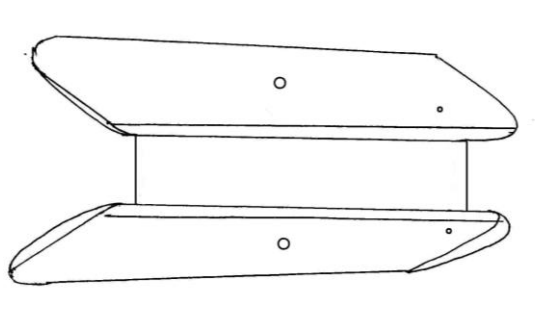

2. Gently run the belt sander with the 120-grain sandpaper back and forth two or three times down the length of the runner blade. Do not run the sander side to side.

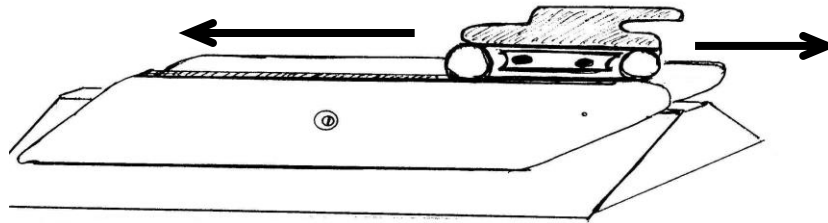

3. Remove the runners and re-attach them to the other side of the trapezoid block.
4. Gently run the belt sander with the 120-grain sandpaper back and forth two or three times down the length of the runner blade. Do not run the sander side to side.
5. Remove the runners and wipe them with lightweight machine oil to keep them from rusting. Sewing machine oil or anything similar works well.